

CT6904A-2 CT6904A-3

AC/DC CURRENT SENSOR

Instruction Manual

EN

Dec. 2021 Edition 1
CT6904G961-00 21-12H



HIOKI

www.hioki.com/



All regional contact information

HEADQUARTERS
81 Koizumi
Ueda, Nagano 386-1192 Japan

HIOKI EUROPE GmbH
Helfmann-Park 2
65760 Eschborn, Germany
hioki@hioki.eu

2111 EN

Edited and published by HIOKI E.E. CORPORATION

Printed in Japan

- CE declarations of conformity can be downloaded from our website.
- Contents subject to change without notice.
- This document contains copyrighted content.
- It is prohibited to copy, reproduce, or modify the content of this document without permission.
- Company names, product names, etc. mentioned in this document are trademarks or registered trademarks of their respective companies.

Warranty

Malfunctions occurring under conditions of normal use in conformity with the Instruction Manual and Product Precautionary Markings will be repaired free of charge. This warranty is valid for a period of three (3) years from the date of purchase. Please contact the distributor from which you purchased the product for further information on warranty provisions.

Introduction

Thank you for choosing the Hioki CT6904A-2, CT6904A-3 AC/DC Current Sensor (800 A rated specification). To ensure your ability to get the most out of this device over the long term, please read this manual carefully and keep it available for future reference.

Carefully read the separate document entitled "Operating Precautions" before use.

Troubleshooting

If the device seems to be malfunctioning, contact your authorized Hioki distributor or reseller.

⚠ DANGER

- If the cable melts, metal parts could be exposed, posing a hazard. Keep the cable away from sources of heat.
- Connect the device to the secondary side of a distribution panel. If a short-circuit occurs on the secondary side of the distribution panel, the panel will interrupt the short-circuit current. Do not connect the device to the primary side of the distribution panel because an unrestricted current flow can damage the device and facilities if a short-circuit occurs.

Do not use the device to measure bare conductors to which a voltage that exceeds the maximum rated line-to-ground voltage is being applied. Doing so could damage the device and cause bodily injury. If the voltage exceeds the maximum rated line-to-ground voltage, measure it using an insulated wire with the appropriate level of insulation for the voltage in question.

⚠ WARNING

Do not place the cable in contact with the measured line. Any contact can cause the device to malfunction and lead to a short-circuit or electric shock.

⚠ CAUTION

- To prevent cable damage, do not step on cables or pinch them between other objects. Do not bend or pull on cables at their base.
- Do not place the device on an unstable or uneven surface. Doing so could cause the device to fall or turn over, causing bodily injury or damage to the device.

- The cable is hardened in freezing temperatures. Do not bend or pull it to avoid tearing its shield or causing a break.
- When the power to lines to be measured is turned on or off, a current flowing through the lines can exceed considerably the maximum allowable current of the device. This could result in damage to the device. Make sure that there is not any over-current.
- Do not apply any current through the lines to be measured with the device turned off. This could result in damage to the device.

Overview

This current sensor has a Hioki ME15W output connector. The sensor has the adequate frequency characteristics and temperature characteristics for not only current measurement but also high-accuracy power measurement.

Specifications

The CT6904A-3 has a 10 m output cable.

Accuracy

Reading (displayed value):
Indicates the value displayed by the instrument. Limit values for reading errors are expressed as a percentage of the reading (" % of reading" or " % rdg").

Range:
Indicates the instrument's range. Limit values for range errors are expressed as a percentage of the range (" % of range" or " % rng").

Full scale (rated current):
Indicates the rated current. Limit values for full-scale errors are expressed as a percentage of full scale (" % of full scale" or " % f.s. ").

Operating environment	Indoor use, pollution degree 2, altitude up to 2000 m (6562 ft.)
Operating temperature and humidity range	-10°C to 50°C (14°F to 122°F) 80% RH or less (non-condensing)
Storage temperature and humidity range	-20°C to 60°C (-4°F to 140°F) 80% RH or less (non-condensing)
Dust resistance and water resistance	IP20 (EN 60529)*1
Standards	Safety: EN 61010 EMC: EN 61326
Withstand voltage	7.4 kV AC (sensed current: 1 mA) 50 Hz/60 Hz for 1 min, between through window and cable output terminal
Power supply	Supplied from PW8001, PW6001, PW3390, CT9555, CT9556 or CT9557 Rated supply voltage: ±11.5 V to ±12.5 V (Tracking) Maximum rated current: ±450 mA (800 A/55 Hz measurement, ±12 V power supply)
Maximum rated power	7 VA (800 A/55 Hz measurement, ±12 V power supply)
Interface	Dedicated interface (ME15W)
Dimensions	Approx. 139W × 120H × 52D mm (5.47"W × 4.72"H × 2.05"D) (excluding protrusions and the cable)
Output cable length	CT6904A-2: Approx. 3 m (including relay box) CT6904A-3: Approx. 10 m (including relay box)
Mounting hole diameter	φ5.2 mm (M5 screw, recommended tightening torque: 1.5 N•m to 2.0 N•m)

Weight	CT6904A-2: Approx. 1.15 kg (40.6 oz.) CT6904A-3: Approx. 1.45 kg (51.1 oz.)
Product warranty duration	3 years
Accessories	• Colored labels (for channel identification) • Instruction Manual • Operating Precautions (0990A907) • Carrying case
Option	Mounting hardware (special-order product)
Memory Function	Sensor information can be read for products with memory function support. Applicable product: PW8001
*1: The protection rating for the enclosure of this device (based on EN 60529) is IP20. 2: Protected against access to hazardous parts with fingers. The equipment inside the enclosure is protected against entry by solid foreign objects larger than 12.5 mm in diameter. 0: The equipment inside the enclosure is not protected against the harmful effects of water.	
Rated current	800 AAC/DC
Measurable conductor diameter	φ32 mm or less
Maximum input current	Not exceeding derating curve shown in Figure 1 However, a current of up to ±1200 A peak (design value) is allowable for up to 20 ms.
Output voltage	2 mV/A
Maximum rated line-to-ground voltage	1000 V (Measurement category III) Anticipated transient overvoltage: 8000 V
Output resistance	50 Ω ±10 Ω
Input impedance	2.5 mΩ typical (100 kHz)
Linearity*2, *3	±12.5 ppm typical (23°C)
Offset voltage*3	±10 ppm typical (23°C, no input)

*2: Measuring the output voltage while cycling the input current (DC) from +800 A → 0 A → -800 A → 0 A → +800 A at an interval of 200 A. Defined as the difference between the regression line calculated from the above measurements and the measurement points.

*3: Defined as a percentage of the rated current.

Accuracy guarantee conditions Accuracy guarantee duration: 1 year
Accuracy guarantee duration after adjustment made by Hioki: 1 year
Accuracy guarantee temperature and humidity range: 23°C ±5°C (73°F ±9°F), 80% RH or less
Warm-up time: at least 30 min
Sine wave inputted, connected with measuring instrument with an input resistance of 0.9 MΩ to 1.1 MΩ, line-to-ground voltage: 0 V, no external magnetic field, conductor arranged at center of window

Measurement accuracy

Frequency	Amplitude ±(% of reading + % of full scale)	Phase
DC	0.030% + 0.009%	-
DC < f < 16 Hz	0.2% + 0.025%	±0.1°
16 Hz ≤ f < 45 Hz	0.1% + 0.025%	±0.1°
45 Hz ≤ f ≤ 65 Hz	0.025% + 0.009%	±0.08°
65 Hz < f ≤ 850 Hz	0.05% + 0.009%	±0.12°
850 Hz < f ≤ 1 kHz	0.1% + 0.013%	±0.4°
1 kHz < f ≤ 5 kHz	0.4% + 0.025%	±0.4°
5 kHz < f ≤ 10 kHz	0.4% + 0.025%	±(0.08 × f)°
10 kHz < f ≤ 50 kHz	1% + 0.025%	±(0.08 × f)°
50 kHz < f ≤ 100 kHz	1% + 0.063%	±(0.08 × f)°
100 kHz < f ≤ 300 kHz	2% + 0.063%	±(0.08 × f)°
300 kHz < f ≤ 1 MHz	5% + 0.063%	±(0.08 × f)°
Frequency range	4 MHz (±3 dB Typical)	-

- The variable f in accuracy equations is expressed in kHz. Full scale indicates the rated current (800 A).
- Amplitude accuracy and phase accuracy are defined for currents of the rated value or less. For currents at a frequency of 100 Hz or greater, they are defined at an ambient temperature of 50°C within the continuous input range as shown in Figure 1, "Frequency Derating." However, design values are given for DC < f < 10 Hz.
- For the CT6904A-3, add an amplitude accuracy of ±(0.015 × f)% of reading for 50 kHz < f ≤ 1 MHz. CT6904A-3 has a frequency band of 2 MHz (±3 dB typical).

Output noise	300 μV rms or less (≤1 MHz)
Effects of temperature	Within the range of -10°C to 18°C or 28°C to 50°C Amplitude sensitivity: ±50 ppm of reading/°C Offset voltage: ±5 ppm of full scale/°C Phase: ±0.01°/°C
Effects of magnetization	5 mA or less (input equivalent, after 800 A DC is input)
Common mode rejection ratio (CMRR)	140 dB or more (50 Hz/60 Hz) 120 dB or more (100 kHz) (Effect on output voltage / common-mode voltage)
Effects of conductor position	±0.01% of reading or less (input current: 100 A with 50 Hz/60 Hz) ±0.2% of reading or less (input current: 10 A with 100 kHz) When using wire with an outer diameter of 10 mm

Effects of radiated radio-frequency electromagnetic field
0.625% of full scale or less at 10 V/m

Effects of conducted radio-frequency electromagnetic field
0.25% of full scale or less at 10 V

Effects of external magnetic field 100 mA or less (input equivalent, under a magnetic field of 400 A/m DC or 400 A/m with 60 Hz)

Connectable products

When connected to an instrument that automatically detects current sensors, the device will be detected as a 1000 A rated sensor.

1. PW8001 Power Analyzer

- 1. U7001 Combined accuracy
U7001 accuracy + sensor accuracy (consider sensor rating for full scale error).
• Additional components should be added to the accuracy depending on the power analyzer and sensor specifications.
- Detected as a 1000 A rated sensor.

-2. U7005 Combined accuracy

Frequency	Current	Power	Phase
	±(% of reading + % of range)		
DC	0.050% + 0.037%	0.050% + 0.037%	U7005 accuracy + sensor accuracy
45 Hz ≤ f ≤ 65 Hz	0.035% + 0.027%	0.035% + 0.037%	
Band other than DC and 45 Hz ≤ f ≤ 65 Hz	U7005 accuracy + sensor accuracy (consider sensor rating for full scale error.)		+ sensor accuracy

- For other measurement parameters, U7005 accuracy + sensor accuracy (consider sensor rating for full scale error).
- For the 20 A range or the 40 A range, add ±0.12% of full scale of the measurement range set on the U7005.
- Additional components should be added to the accuracy depending on the power analyzer and sensor specifications.
- Detected as a 1000 A rated sensor.

2. PW6001 Power Analyzer

Combined accuracy

Frequency	Current	Power	Phase
	±(% of reading + % of full scale) (full scale = PW6001 range)		
DC	0.050% + 0.037%	0.050% + 0.057%	PW6001 accuracy + sensor accuracy
45 Hz ≤ f ≤ 65 Hz	0.045% + 0.027%	0.045% + 0.037%	
Band other than DC and 45 Hz ≤ f ≤ 65 Hz	PW6001 accuracy + sensor accuracy (consider sensor rating for full scale error.)		+ sensor accuracy

- For other measurement parameters, PW6001 accuracy + sensor accuracy (consider sensor rating for full scale error).
- For the 20 A range or the 40 A range, add ±0.12% full scale of the measurement range set on the PW6001.
- Additional components should be added to the accuracy depending on the power analyzer and sensor specifications.
- Detected as a 1000 A rated sensor.

3. PW3390 Power Analyzer

Combined accuracy

- PW3390 accuracy + sensor accuracy (consider sensor rating for full scale error)
- Additional components should be added to the accuracy depending on the power analyzer and sensor specifications.
- Detected as a 1000 A rated sensor.

4. CT9555, CT9556, or CT9557 Sensor Unit

Combined accuracy

- For the CT9555, use the sensor accuracy. For the CT9556/CT9557, add ±0.01% of reading to the sensor accuracy (when the output coaxial cable is 1.6 m or less in length).
- For the CT6904A-3, the frequency band is 1 MHz (±3 dB typical).
- Additional components should be added to the accuracy depending on the connected device and sensor specifications.

Figure 1. Frequency Derating

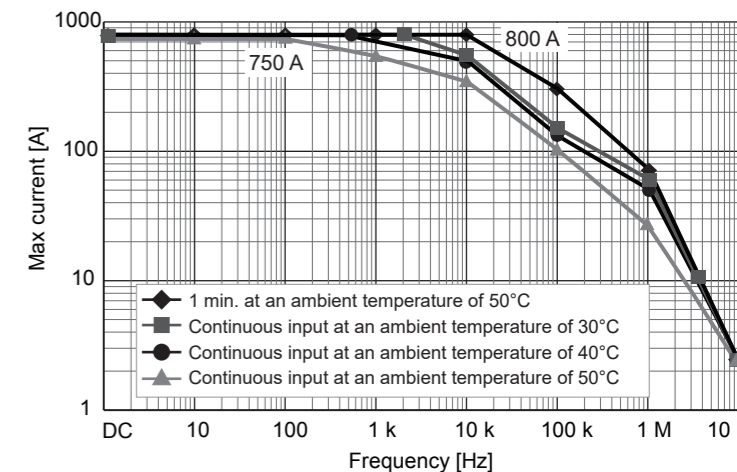

When measuring current close to the derating, allow a cool-down time of at least 10 times the time for which the current was input.

Phase Compensation Values

Enter the following compensation values (characteristic values) when performing phase compensation on the PW6001 or PW3390.

300kHz, -9.82° (CT6904A-2, CT6904A-3 common)

The 300 kHz phase measured value noted in the test report can be used as the phase compensation value. In theory, using this value will allow more accurate measurement than is possible when using the representative value. There's no need to enter compensation values for the PW8001 as that instrument reads sensor information from memory and performs compensation automatically.

Characteristics (CT6904A)

Frequency characteristics (Typical)

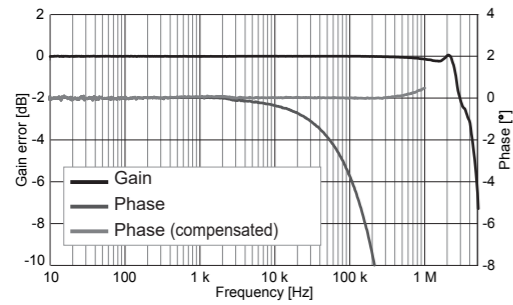

CMRR (Typical)

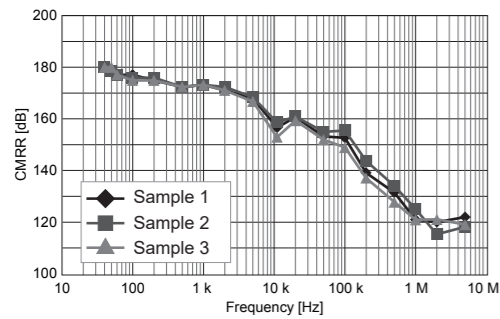

Effects of conductor position (Typical) (at 100 kHz)

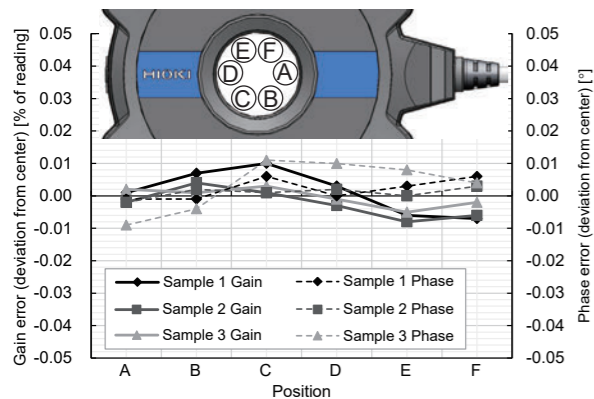

Linearity error (Typical)

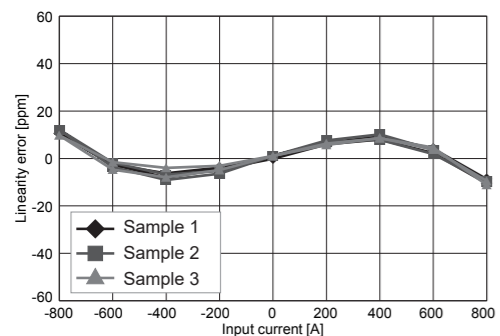

Part Names and Dimensions

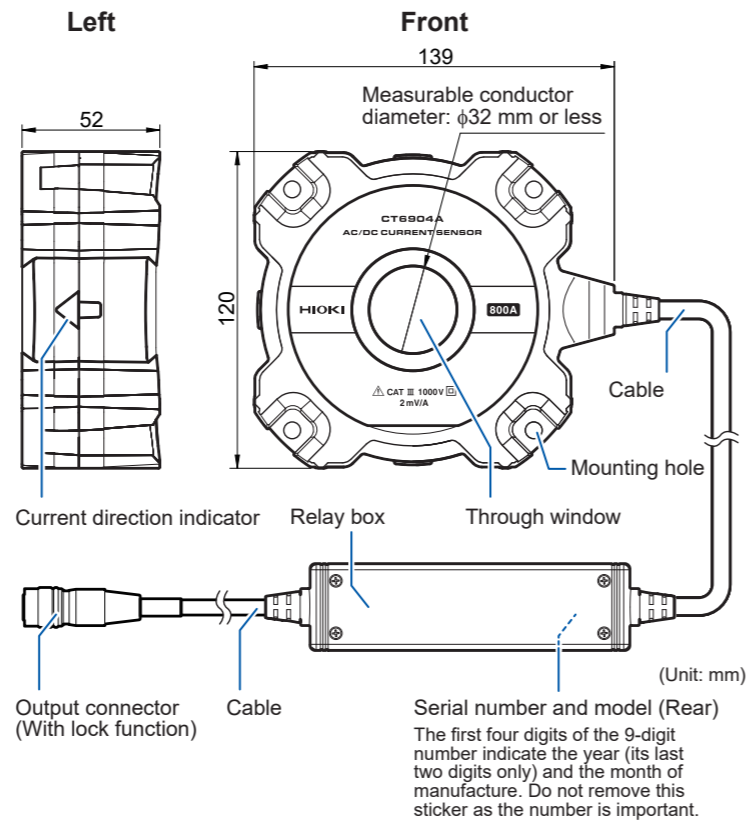

Mounting hole dimensions

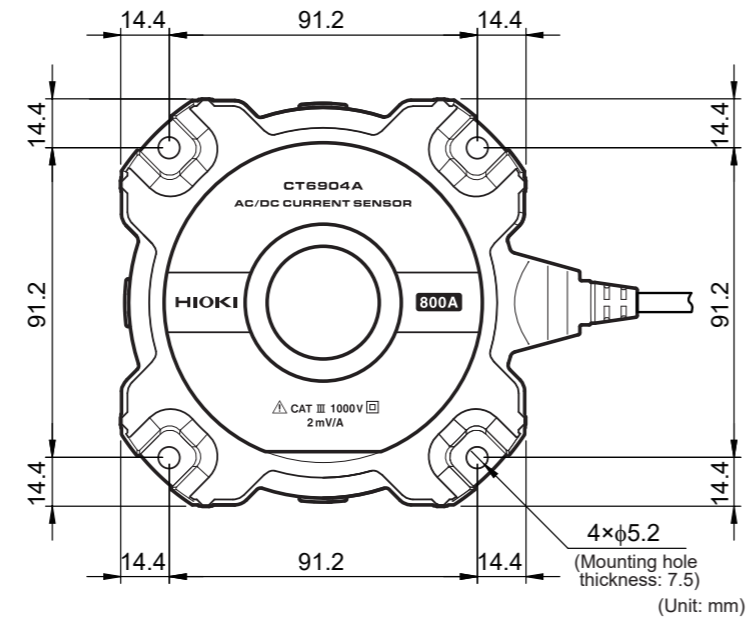

Mounting hardware dimensions (Option)

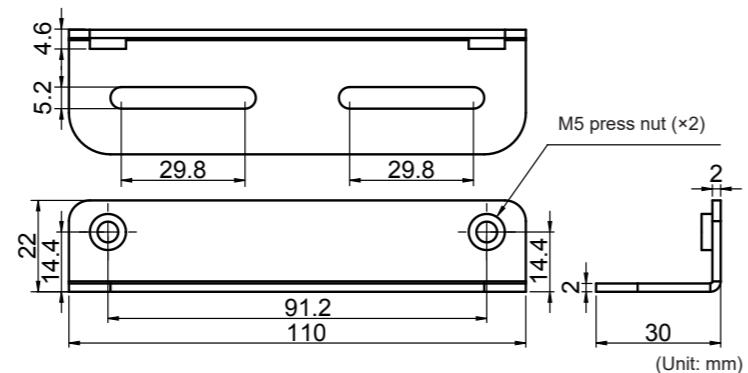

Example Installation/Mount

To facilitate high-precision measurement, the measured conductor must be as short as possible. Determine how to mount the device so that the measured conductor is as short as possible.

Recommended tightening conditions

Nominal screw size: M5
Screw length: 20 mm or more
Tightening torque: 1.5 N \cdot m to 2.0 N \cdot m
Use a washer and lock washer

There are two ways to mount the sensor:

1. Using the mounting hardware

The sensor can be mounted in four orientations.

Orientation 1

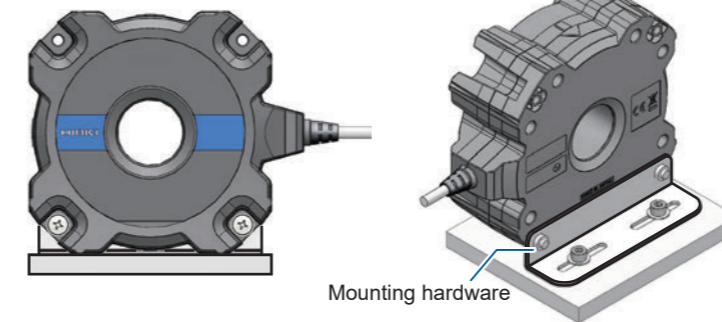

Orientation 2

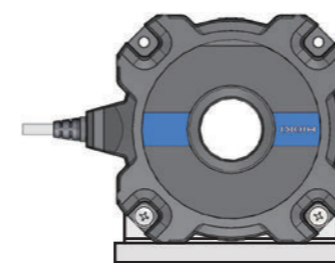

Orientation 3

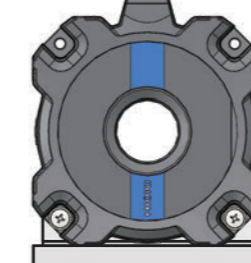

Orientation 4

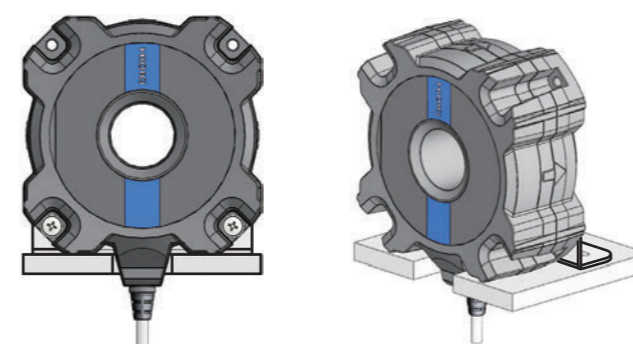

2. Mounting directly

The sensor can be mounted in the desired orientation.

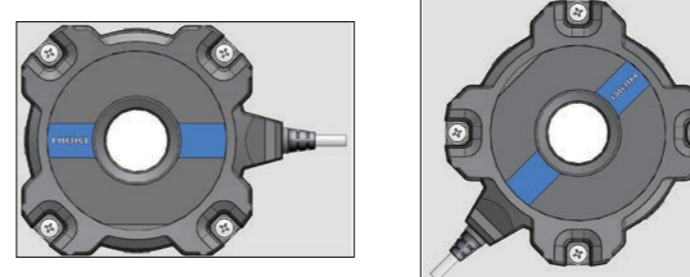

Measurement Procedure

Inspection Before Use

Check the device for any damage that may have occurred during storage or shipping before use. If you find any damage to the device, please contact your authorized Hioki distributor or reseller for repair.

Check Items	Remedy
Is the device cracked or damaged?	If there is any damage, electric shock may result. Discontinue use and contact your authorized Hioki distributor or reseller.
Is the cable insulation torn?	Broken connections will make proper measurement impossible. Discontinue use and contact your authorized Hioki distributor or reseller.
Is the cable broken at the base (of the connector or the sensor)?	Discontinue use and contact your authorized Hioki distributor or reseller.

Wiring

Make sure the direction of the arrow on the case matches the direction of the current flow, as shown in the figure below. If they are oriented incorrectly, the output signal from the sensor will be reversed. When using the device in combination with a power meter, conform to the power meter's wiring method.

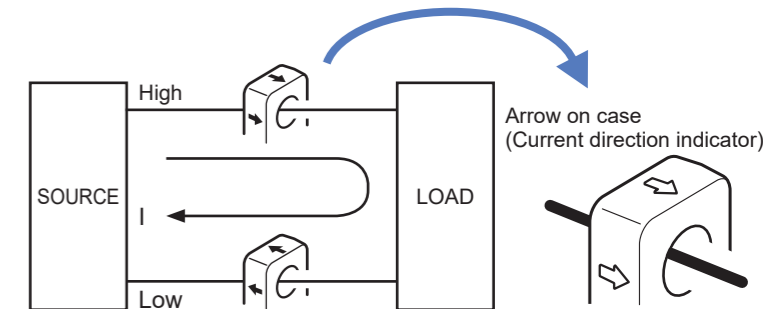

IMPORTANT

